

# Installation Manual (V2.2)

## PAB-BD Beyond

### Barrier Gate



# Contents

1 Declaration	2
2 Safety	3~4
3 Packing	5
4 Installation	6~7
4.1 Structure Of Barrier	6
4.2 Arm Installation direction	6
4.3 Foundation	6~7
4.4 Power connection	7
5 Specification, Feature & Function	8~12
5.1 Technical Specification	8
5.2 Function & Features	9~12
6 Operation	13~19
6.1 Safety tips	13
6.2 Boom arm assembly	13
6.3 Adjust boom length	14
6.4 Adjust boom direction	15
6.5 Controller Board and wiring Diagram	16
6.6 Parameter programming	17~18
6.7 Self-Learning Remote Control	19
7 Maintenance and repair	20~22
7.1 Maintenance	20
7.2 FAQs and troubleshooting	21~22
8 Mechanical explosion drawings and parts list	23~24
9 Electrical diagram and parts list	25

# 1. Declaration

- The original language is English.
- Machine noise: less than 60db.
- Not more than 1000m above sea level, can not be used in explosive environment.
- EU single-phase voltage is 230V.

## EC DECLARATION OF CONFORMITY



According to the following EC Directives

- Low Voltage Directive: 2014/35/EU
- Electromagnetic Compatibility Directive 2014/30/EU

**The undersigned, Tan Qi Hua , representing Xiamen Dashou Technology Ltd./ The 2nd Floor, No. 882 , 2nd Tonglong Road, Torch High-Tech Zone (Xiang`an) Industrial Park,Xiamen China . Declares that the machine described hereafter:**

**Product name: Barrier Gate**

**Model:** PAB-BD-NSN, PAB-BD-NSL, PAB-BD-SHSN, PAB-BD-HSN ,PAB-BD-HSL, PAB-BD-NCN, PAB-BD-NCL, PAB-BD-HCN, PAB-BD-HCL, PAB-BD-NFN,PAB-BD-HFN, PAB-BD-NFN2

Provided that it is used and maintained in accordance with the general accepted codes of good practice and the recommendations of the instructions manual, meet the essential safety and health requirements of Low Voltage Directive and Electromagnetic compatibility Directive.

Person authorised to compile the technical file: Qihua Tan, The 2nd Floor, No. 882 2nd Tonglong Road, Torch High-Tech Zone (Xiang`an) Industrial Park, Xiamen China

For the most specific risks of this machine, safety and compliance with the essential requirements of the Directive has been based on elements of:

**EN 60204-1:2018**

**EN 61000-6-3:2007+A1:2011**

**EN 61000-3-2:2014**

**EN 61000-3-3:2013**

**EN 61000-6-1:2007**

Date: 2019-04-24

Signature: Tan Qi Hua

Qualification: General Manager

## 2. Safety

### 2.1 General safety information

This PAB-BD series barrier was designed, built and tested using advanced technology and will have left our factory only after having satisfied stringent safety and reliability criteria. Nevertheless the barrier system can represent a risk to persons and property if it is not operated correctly. These operating instructions must therefore be read in their entirety and all safety information contained therein must be complied with.

The manufacturer shall refuse to accept liability and shall withdraw warranty cover if this barrier system is used incorrectly or is used for a purpose for which it was not intended.

### 2.2 Intended Use

The PAB-BD series barriers are designed for use in controlling the entrance and exit lanes of car parks areas, multi-storey car parks and other vehicular access routes.

It is not permitted to use these barrier systems for any other purpose. Modifications or changes to the barrier or its control modules are prohibited. Only original Dashou spare parts and accessories may be used.

### 2.3 Operational Safety



A safe clearance distance, of at least 500 mm, must be provided between the top of the barrier boom and the closest solid obstacle (building, wall, fence etc.). The barrier activating elements must be installed at a position that provides a direct line of site to the barrier.

The motion of the barrier boom must be directly visible to the person operating the barrier. Whilst the barrier boom is in motion, persons, and other objects, are prohibited from being in the immediate vicinity of the barrier.

Automated systems must be provided with a specially marked pedestrian walkway (actual location to be determined on-site).

If the barrier and operating elements have been installed, and connected in a fixed mains power supply, an all-pole, lockable, electrical master switch must be used.

The assembly and installation instructions must be complied with in their entirety. Permission must be sought from Dashou, prior to any alterations.

Barrier booms longer than 3.5 m require a supporting bracket.

All electrical connections, wiring work and exchange of any components may only be performed by appropriately trained electrical technicians.

Before opening any electrical or electronic modules within the barrier, they must first be disconnected from the mains power supply.

Technical modifications or changes, to the barrier system, are prohibited.

## 2.4 Technical Developments

The manufacturer reserves the right to modify, without prior notice, the technical specifications in order to accommodate the latest technical developments. Dashou is willing to provide information on the status of existing operating instructions and on any alterations and extensions that may be relevant.

## 2.5 Warranty

**Definition of warranty duration:** All products for signed distributors of DASHOU have 12 months warranty from loading date of shipment. Warranty does not cover problems arising after above durations. Besides, the warranty terms agreed between the distributors and their customers are beyond the liability of DASHOU.

**Maintenance of Products:** If Products are originally defective, it shall be substituted or repaired as the occasion requires during the warranty period. (Note: For the substitution, repairing, they would be covered by DASHOU. For the transportation, the customer will pay the shipment charge from local to Dashou and DASHOU will pay the shipment charge from DASHOU to the customer.)

For any Products of which the warranty period has expired, it may be repaired with charge, only the electric components' fee. In any of the following events, the defective product is beyond the scope of warranty:

- ☆ The marker or serial number of the defective product is unclear or has been altered;
- ☆ Damage attributable to any personal reason other than any intrinsic defect;
- ☆ Damage incurred by other reasons, accidental damage, abnormal use or installation.

In case it's necessary for DASHOU to dispatch technicians to participate at the customer's side without quality problems, the expenses shall be borne by the customer.

### 3. Packing

PAB-BD barrier housing uses corrugated cardboard box with cushioning material packaging for packaging, and boom arm uses bubble plastic film for packaging (poly wood package will be provided upon customer's cost if required). Below parts are the dimensions of the packing box and barrier:

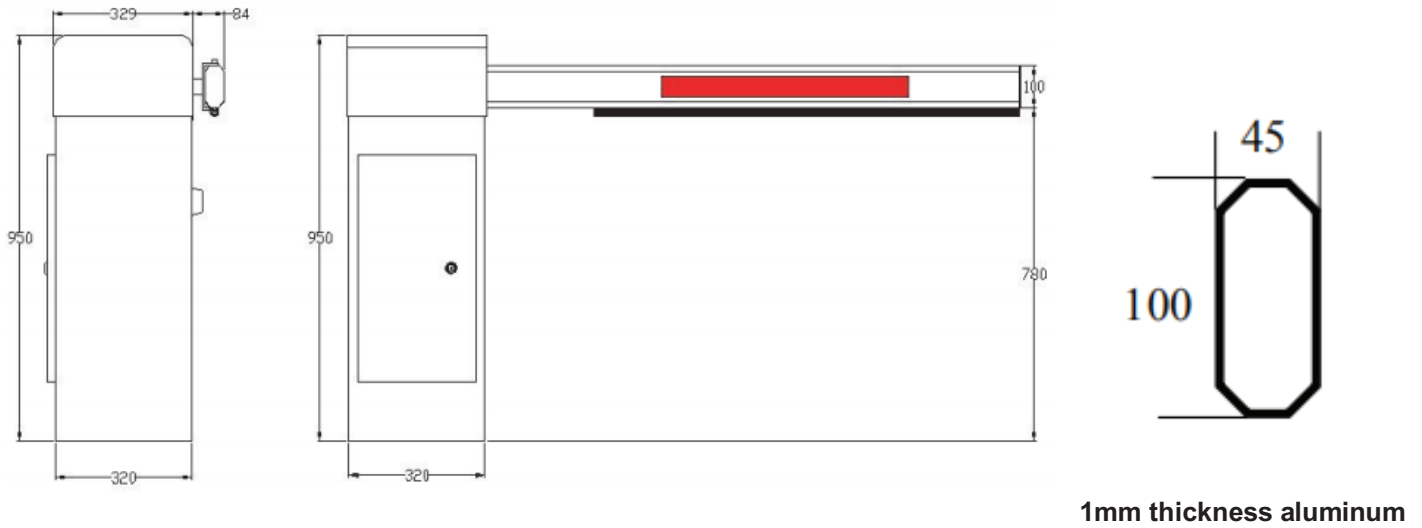

Dimensions of barrier housing & boom arm (mm)

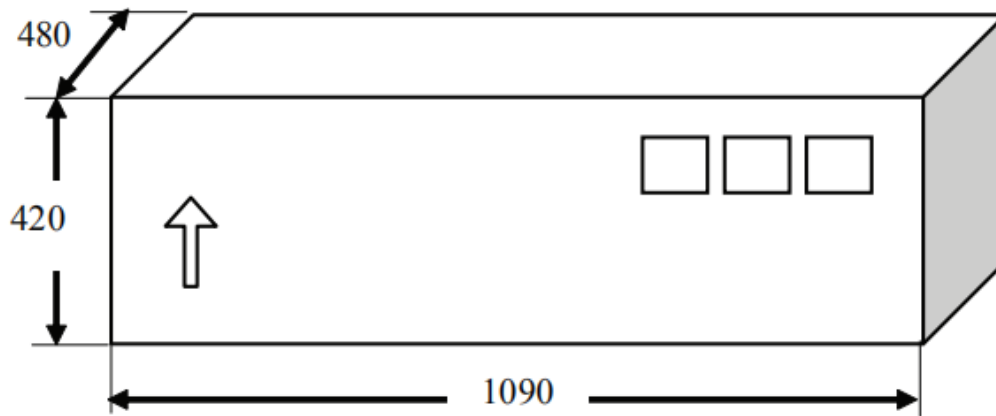

Dimensions of packing box (mm)

Following accessories should exist when open the package:

- 4 PCS. M16 X 120mm expansion bolt used to fix barrier housing onto foundation
- 4 PCS. M8 X 60mm(For fence arm) or M8 X 20mm(For straight/Crank arm) hexangular lock screw used to assembly boom
- 1 PC Boom Lining for boom fixing
- 1 PC end cap of boom
- 1 PC key to barrier housing door
- Other optional accessories if customers buy

# 4. Installation

## 4.1 Structure Of Barrier

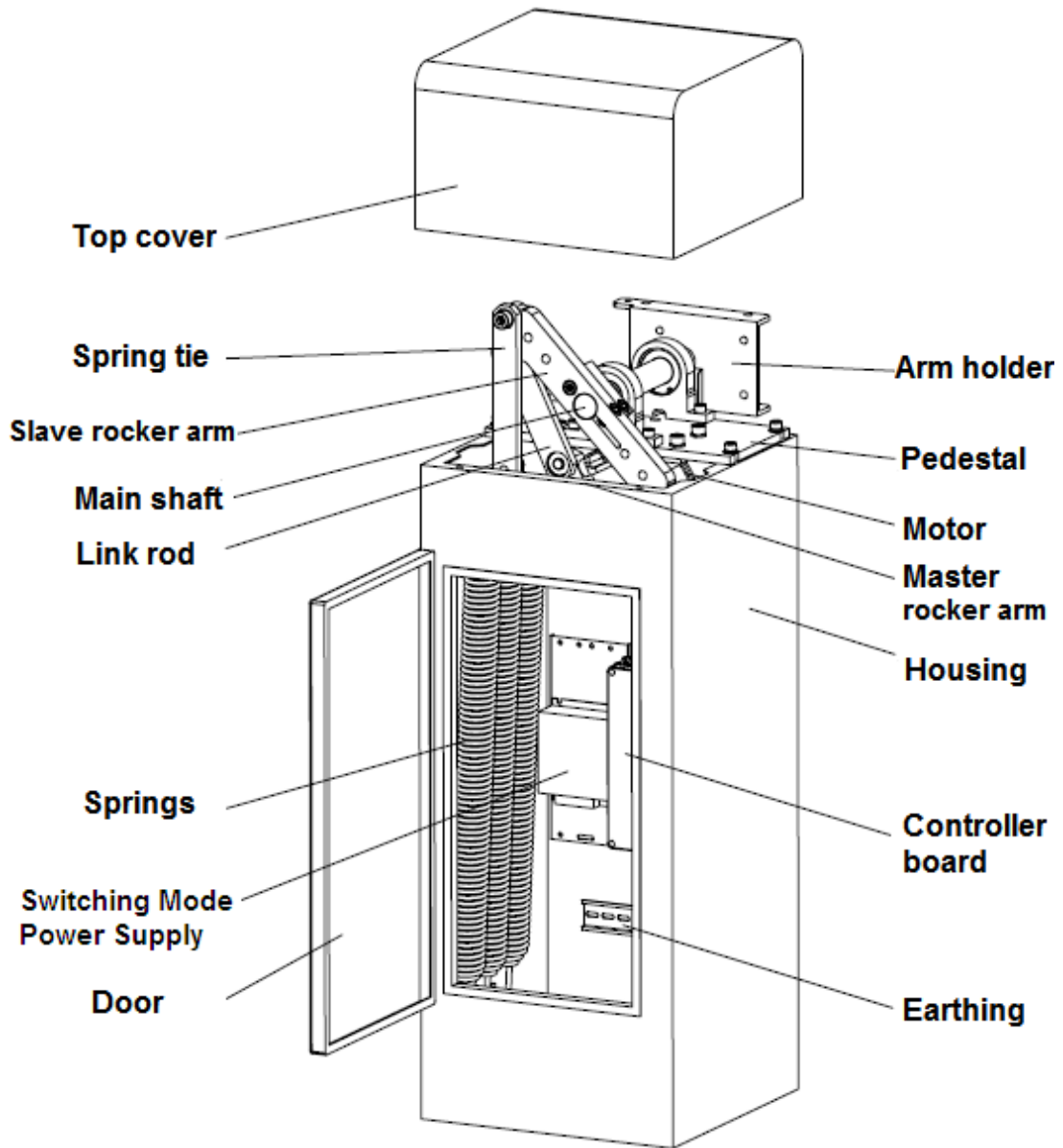

## 4.2 Arm Installation Direction

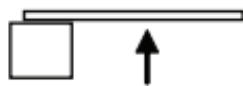

a) Leftward

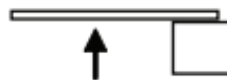

b) Rightward

## 4.3 Foundation

To ensure that the barrier gate is working stably under all operating conditions, a concrete foundation with the following dimensions must be provided:

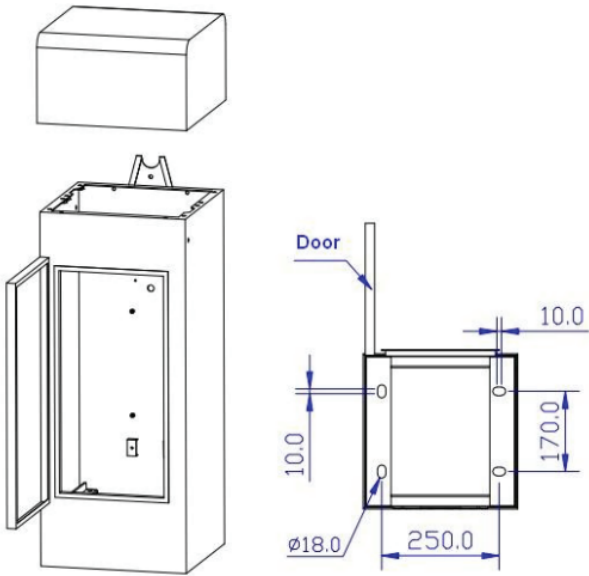

Foundation diagram ( mm )

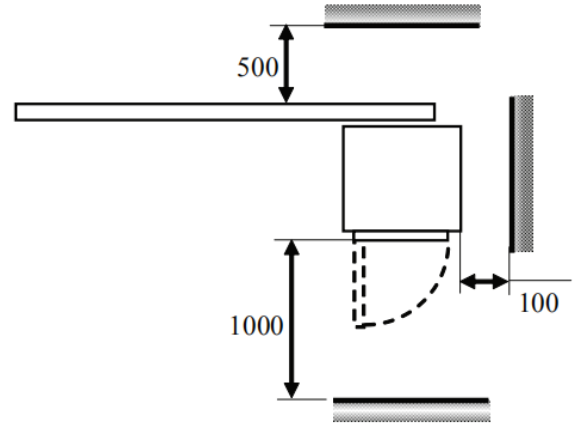

Minimum Installation Space(mm)

1. Fix those 4PCS expansion bolt (M16\*145) on the concrete foundation according to above Foundation Diagram in "4.3 Foundation";
2. Align the bottom hole of the barrier to those 4PCS expansion bolt, lock and fasten them by nuts. Please be sure that the barrier can work steady.

#### 4.4 Power Connection

PAB-BD Beyond barrier uses AC90~240V & 50/60HZ input as its power supply. A fuse has integrated by barrier controller unit. For the safety and ease of maintenance and repair, barrier has set the auto-breaker and safety switch in power supply circuit.

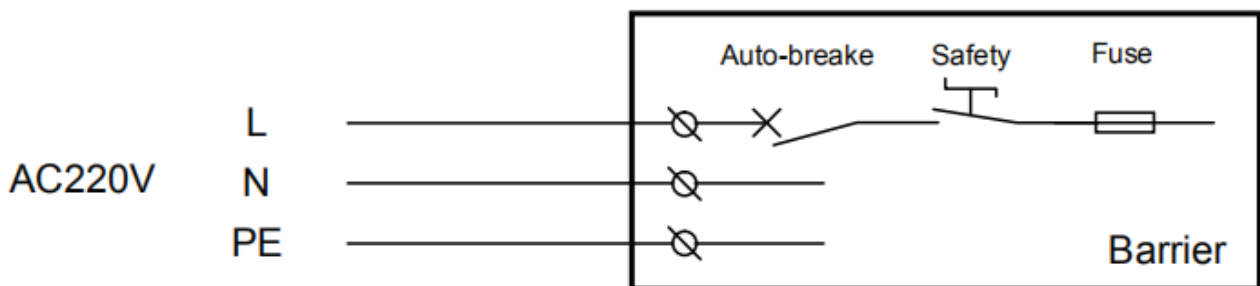



## 5. Specification, Features & Function

### 5.1 Technical specification

Power Supply	AC100~240V, 50-60HZ, Max.0.65A
Motor (DC 24V±10%)	50W standard torque brushless motor
Control unit	80C51 MCU, 20Mhz basic frequency, PWM variable frequency servo motor technology, multiplexing 0~5V switch input, multi relay output; No isolated RS485 communication interface, WatchDog shut down protect.
Loop detector input	Either active or passive dry contact input; 0~0.5V or short as logic 0, 3V~24V or open as logic 1. The input has RC hardware filter and 10 ms software filter, the width of pulse required to be over 100 ms, 1 fall to 0 trig to protect from crash to obstructer, and 0 to 1 trig barrier boom to move up.
Infrared Photocell input	Either active or passive dry contact input, 0~0.5V or short as logic 0, 3V~24V or open as logic 1. The input has 10 ms software filter, the width of pulse required to be over 100 ms, 1 fall to 0 trig to protect from crash to obstructer, and 0 to 1 trig barrier boom to move up.
Up & Down input	Either active or passive input, 0~0.5V or short as logic 0, 3V~24V or open as logic 1. The input has 10 ms software filter, the width of pulse required to be over 100 ms, 1 fall to 0 trig
Traffic light output Loop detector Syn. output	AC 220V power output (passive), Max. current 3A/ AC220V. Relay works if barrier boom move >2/3 and releases if boom move <2/3. Relay NO output, Max.AC 220V/0.5A, Max.DC 12V/1A
WIFI & TCP/IP interface (optional)	Barrier can be controlled by smart phone with WIFI interface, and controlled by PC with TCP/IP interface
RS 485 interface	Semi-duplex RS485 interface, switch time 10 ms, 8 data bits, 1 stop bit, no checksum, 9600 bps, ASCII decimal code.
Opening/closing time	0.9 to 6 seconds frequency conversion stepless speed regulation
Wireless Remoter (optional)	Two button remote transmitter, distance: 20~50m
Spring	1~3 pcs. springs according to boom length
Arm	45×100mm Aluminum alloy arm(Max. 6m) 50mm diameter round arm(Max. 3.5m)
Arm direction	Left/right exchangeable
Housing	2mm cold-roller sheet, anti-UV light and static plating, IP 54
Housing dimension	950mm×329mm×320mm
Gross Weight	Around 46 KG
Operating temperature	-40°C -75°C
Humidity	10%-95%

## 5.2 Function & Features

### 5.2.1 Smartphone Control & Program Smart Barrier (Optional)

The barrier gate can be connected to your smartphone via WIFI, so you can open and close barrier gate on your smartphone. You can also program the barrier on your smartphone such as setting opening/closing time.

\*Dashou App should be installed in your smartphone, and WIFI module should be installed in barrier controller.

Video link: [https://youtu.be/S81OPX\\_3f8E](https://youtu.be/S81OPX_3f8E)

### 5.2.2 TCP/IP RJ45 Port for Easy Integration (Optional)

The barrier provides optional TCP/IP RJ45 port, which can integrate the barrier with your own system conveniently, so you can control barrier by your own system. You can even remotely monitor the status of barrier.

\*Ethernet module should be installed in the controller, and communication protocol will be provided by Dashou.

### 5.2.3 Free-maintenance Brushless DC Servo Motor

Free-maintenance brushless motor, integrated angle encoder inside, full digital servo control, no contact or non-contact sensor for in-position detection, no electrical maintenance, and avoid all kinds of wear and hazards.

Free-maintenance DC24V brushless servo torque motor ensures 10 million cycles MTBF long life span; 100% duty cycle makes barrier continuously work at 24\*7 hours; Max. 50W super low consumption makes barrier environment friendly but outputs super strong torque.

### 5.2.4 Opening/Closing Time is Adjustable Thanks to PMW Variable Frequency Servo Controller

The barrier gate adopts digital frequency conversion servo controller, which allows the stepless speed control of the drive motor under the condition of no loss of output torque, and the opening time and closing time can be respectively adjustable 1~4 or 2~6 sec. on the controller or APP (APP is optional).

Video link: <https://youtu.be/XWK4bS4882g>

### 5.2.5 PMW Variable Frequency Servo Controller Ensures Smooth Movement of Boom

The smoothness of opening and closing can be programmed separately. After programming, regardless of speed, the frequency conversion servo controller can automatically detect the self-optimization, and automatically eliminate the boom shocking, which not only enhances the intelligent experiences, but also significantly extends the mechanical and electrical life of barrier gate.

### 5.2.6 Automatically check operation status and report error

Barrier system will automatically check its operation status and show errors code on its LED tube if an error occurred. This helps you quickly find out problem and find solution. List of failure code as below:

E1---Pulse angle sensor or motor failure;

E3---'up' input failure (Input short circuit remains more than 10 sec. regarding as fail)

E4---'down' input failure (Input short circuit remains more than 10 sec. regarding as fail)

E5---"1# Loop Detector" input failure (Input short circuit remain more than 10 sec. regarding as fail)

E6---"Infrared photo cell" input failure (Input short circuit remain more than 10 sec. regarding as fail)

E7--- Always-on mode

### 5.2.7 Multiple Control Method

Five ways to control the barrier movement:

- 'Up' and 'Down' inputs by a push button
- Remote control
- RS485 serial command.
- WIFI control
- TCP/IP control

### 5.2.8 Boom Automatically Reverse On Obstacles

While moving down, boom arm will immediately go back to vertical position once it is obstructed by an imposed force, which protects the vehicle or person not to be hit by boom arm. The sensitivity is adjustable. Note: This function does not work when the angle is  $<9^\circ$  both in vertical and horizontal position.

Video link: <https://youtu.be/7XLsrqrP1LM>

### 5.2.9 Boom Swing off To Protect Boom & Vehicle (optional)

If a swing-off module was installed, boom will swing off 90 degree if it was hit by a vehicle, this is to protect both vehicle and boom. It is optional. You can easily add swing-off module to a barrier which is without swing-off.

Video link: <https://youtu.be/AM00gZ1PP2U>

### 5.2.10 Alarm When Boom Swing Off (Optional)

Suppose "swing-off module" & "alarm against swing-off module" were installed together in the barrier, boom will swing off 90 degree and alarm will be triggered if the boom was hit by a vehicle, this is to protect both vehicle and boom. It is optional. You can easily add these two modules to a barrier which is without them.

### 5.2.11 Manually Control In Case of Power Failure

Once power is off, just open the cabinet and manually turn the manual/lock lever handle in the power-off state, and the arm will follow. The arm can be locked in any position between horizontal and vertical. When the barrier motor is stopped, lock down the lock lever button of the manual/lock lever handle, and the barrier is locked. Even if it is energized, it will not be unlocked. To unlock, unlock the lock lever button of the manual/lock lever handle.

**Warning: Not allowed to use the function when power on, may hurt your hand and damage the motor**

### 5.2.12 Automatically Open When Power off (optional)

If power is suddenly off while boom closing, boom will automatically close down fully if the angle between boom and vertical plane beyond 45 degree. If power failure occurs during boom opening, boom will automatically continue to open up fully if the angle between boom and level surface beyond 45 degrees.

Video link: [https://youtu.be/s6JthTjK\\_0s](https://youtu.be/s6JthTjK_0s)

### 5.2.13 Boom will be automatically locked in case of power failure

It can not work together with function 5.2.10 at the same time.

Video link: [https://youtu.be/RsBwN\\_ksp3g](https://youtu.be/RsBwN_ksp3g)

### 5.2.14 Boom Direction Is Exchangeable Without Replacing Any Parts

In the past you have to keep stock for barriers with different boom direction as different sites may require different boom direction. But now boom arm direction can be exchanged easily at site without replacing any parts.

Video link: <https://youtu.be/Q3pKwgcZ1SM>

### 5.2.15 Easily Change Boom Type At Site (optional)

The default arm holder is universal, allowing user to expand or replace arm holder's accessories on site, to change to different kinds of arm, such as octagonal, round, swing-away, folding and fence arm.

How to Add Swing-Off Module Without Replacing Any Part. Video link: <https://youtu.be/BYmxsxAQLrE>

How to Change Into Round Boom Without Replacing Any Part. Video link: <https://youtu.be/YVFa8GLp4Gc>

How to Change into Fence Boom Without Replacing Any Part. <https://youtu.be/839ILD1M3ag>

How to Change into Crank Boom Without Replacing Any Part. <https://youtu.be/7Qd4VGjtmIq>

### 5.2.16 Safety--- Anti-hit by Loop Detector (Optional)

Suppose 1# loop detector is connected to the barrier gate. While barrier boom moving down, If a coming vehicle was detected to be existing on the ground induction coil (to be connected to 1# loop detector), the barrier boom will go back to vertical position immediately until loop input was dismissed and then the barrier boom will go down immediately. Note: This function does not work when barrier boom horizontal angle is  $<9^\circ$ .

### 5.2.17 Safety--- Anti-hit by IR photocell (Optional)

Suppose a Photo Cell is connected to the barrier gate. While barrier boom moving down, If infrared transportation between transmitter and receiver is blocked by human or vehicle, the barrier arm will go back to vertical position immediately. The arm will automatically close once the infrared transportation recovers. Note: This function does not work when barrier boom horizontal angle is  $<9^\circ$ .

### 5.2.18 Double safety--- Anti-hit by Loop Detector & IR photocell (Optional)

To double protect a vehicle by connecting a loop detector and an IR photocell to barrier gate. While barrier boom moving down, if the infrared transportation between transmitter and receiver was blocked by a coming vehicle, or the coming vehicle was detected to be existing on the ground induction coil, or both happened, the barrier arm will go back to vertical position immediately. The arm will automatically & immediately close once the infrared transportation recovers and at the same time the vehicle has already passed through the ground induction coil.

### **5.2.19 Safety--- Anti-hit by “Opening Priority”**

If a vehicle is coming while boom arm moving down, the boom arm will immediately go back to vertical position once a manual open command is given by guard by the push button or remoter transmitter, which protect the vehicle not to be hit by boom arm.

### **5.2.20 Automatically close after the given time**

Once this function is set “ON”, the barrier will automatically close after given time (1-90 seconds adjustable) if there is no any up or down input after barrier open fully. This function is OFF as a default.

### **5.2.21 Automatically Close by 1# loop detector (Optional)**

If 1# loop detector is connected to barrier gate (connect 1# loop detector to “Loop 1” terminal of controller board. Refer to 6.4 for details), if no any up or down input after the boom opened fully, the barrier will automatically close after vehicle passed.

### **5.2.22 Automatically open by 2# loop detector (Optional)**

If 2# loop detector is connected to barrier gate (connect 2# loop detector to “Loop 2” terminal of controller board. Refer to 6.4 for details), once 2# loop input was triggered when barrier boom is in horizontal position, the barrier boom will open automatically and immediately.

### **5.2.23 Always-open mode (Optional) Keep continuously pressing**

“Stop” button of remote transmitter for 3 seconds, boom arm will go up to vertical position and stay there until again keep pressing “Close” button of remoter transmitter for 3 sec. to finish always-open mode.

### **5.2.24 Traffic light control (Optional)**

When barrier boom go up more than 2/3, the relay shorted, the port connected to the green light output will be AC 220V, the port connected to the red light will no output; When barrier boom go down more than 1/3, the green light will no output, and the red light output will be AC 220V.

### **5.2.25 Backup Solar Panel or Lead-acid Cell (Optional)**

DC motor barrier can be powered by solar panel or lead-acid cell for backup power supply. Especially solar power is environment friendly which is good for earth.

### **5.2.26 Anti-condensation in cold climate**

The barrier remains low power consumption even without closing and opening input, which will keep the motor in normal temperature. The lubricant will not be frozen so that barrier will keep working in frozen environment

## 6. Operation

### 6.1 Safety tips

Prevent smashing by boom arm: don't stand under the boom arm while it is moving down.



Prevent electric shock: barrier using non-secure AC220V as power supply, the wiring terminals and control board will be electrified with non-secure voltage after power, don't touch these parts after power.



Prevent mechanical injury: there are many exposed mechanical parts will have dislocation movement while barrier is at work. don't touch these while at work.



### 6.2 Boom Arm Assembly (Without Swing-off)

1. Insert the boom lining into the boom arm and align the four mounting holes at the upper and lower.
2. Put the boom arm into the boom holder and re-align the four mounting holes at the upper and lower. Lock and fasten the boom arm using 4pcs boom locking screws.
3. Push the boom cover into the boom arm.

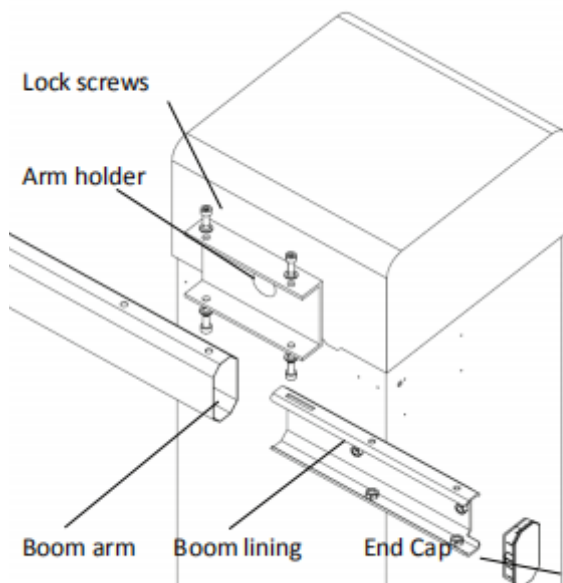

#### CAUTION:

- The boom arm must be installed in a vertical position or when the spring is completely loosen!

Otherwise, the counter-electromotive force generated by the motor rotating rapidly due to the spring tension will burn the controller!

- If balance spring has been installed but no boom arm installed onto barrier, this may burn the controller board.

## 6.3 Change Boom Length

Before delivery, parameters have been programmed well according to the boom length required by customers. If you need to change the boom length, you must follow below steps:

6.3.1 Under status of Power-off, remove the boom from the barrier gate and cut boom to desired length and then assembled to barrier gate. **(Refer to 6.2 Boom arm assembly)**

6.3.2 Select appropriate quantity of balance spring according to boom length, and hang springs to barrier:

BOOM TYPE	BOOM LENGTH (MTR.)	SPRING DIAMETER (MM)	SPRING QUANTITY (PCS.)
Octagonal straight boom	3	3.5	2
Octagonal straight boom	3.5	3.5	3
Octagonal straight boom	3.5	5.0	1
Octagonal straight boom	4~5	5.0	2
Octagonal straight boom	5.5~6	5.0	3
Octagonal 2-fence boom	4	5.0	3
Octagonal 1-fence boom	4.5	5.0	3
Octagonal folding boom	3	Spring diameter and spring quantity depends on the length of each part of folding boom	
Octagonal folding boom	3.5		
Octagonal folding boom	4		
Octagonal folding boom	5		

### 6.3.3 Adjust Balance of Spring

Firstly make sure boom is at vertical position and power is off, then rotate manual handle to move boom down till it keeps static at 45°. If boom can stop in  $\pm 15^\circ$  range when softly push down or lift up boom for 0.5 sec., it means spring is already balanced (Power on barrier, it will open/close normally). Otherwise you have to adjust spring tightness according to below steps:

#### **Spring is too loose, need to tighten spring**

Power off barrier, rotate manual handle to move boom down till it keeps static at 45 degree. If boom can not stop in  $15^\circ$  range when softly push down boom for 0.5 sec., it means spring is too loose, just tighten spring and do step 6.3.3 again till spring is balanced.

#### **Spring is too tight, need to loosen spring**

Power off barrier, rotate manual handle to move boom down till it keeps static at 45°. If boom can not stop in  $15^\circ$  range when softly lift up boom for 0.5 sec., it means spring is too tight, just loosen spring and do step 6.3.3 again till spring is balanced.

See video of how to Adjust Balance of Spring at <https://youtu.be/S6DO1YDhOFM>

## 6.4 Adjust Boom Direction

The boom direction has been set properly according to customer requirements. If the boom direction does not match to the site, please adjust the boom direction as follow steps: [See video at https://youtu.be/Q3pKwgcZ1SM](https://youtu.be/Q3pKwgcZ1SM)

- 1) Remove the boom when the power is off and spring is loose.
- 2) Remove the spring and spring tie, move and hang it to the other side of weight rocker.
- 3) Install the boom, and Loosen the main shaft holding block and the counterweight rocker and rotate the arm to the desired position, locking the main shaft holding block and rocker.
- 4) Adjust the spring balance according to the point 6.3
- 5) Power on and set the opposite boom direction mode(C0) on controller. See video at [https://youtu.be/FuAIO\\_tVYDA](https://youtu.be/FuAIO_tVYDA)

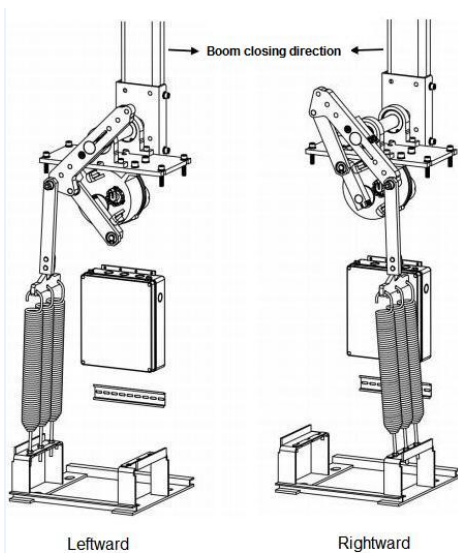

C0—Boom direction programming mode  
00=rightward, 01=leftward

Note:

The boom arm must be installed in a vertical position or the spring is completely loosen!

Otherwise, the counter-electromotive force generated by the motor rotating rapidly due to the spring tension will burn the controller!



## 6.5 Controller Board & Wiring Diagram

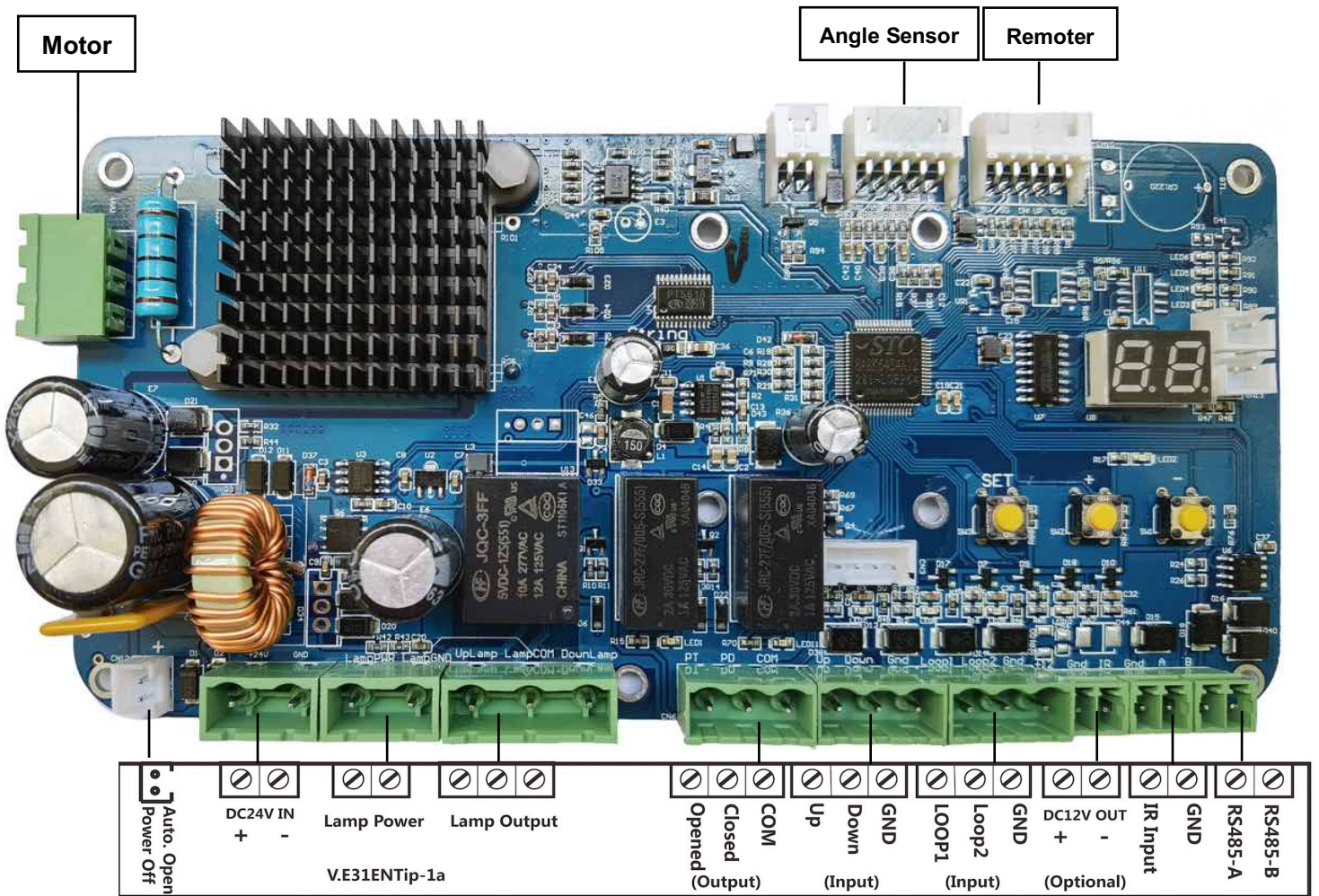

Caution: When setting the parameters, the parameters will not be recorded until the Led digital tube displays 0

Note: Continuously press "SET" button of the controller for 1 second, to show barrier software version.

## 6.6 Parameter Programming

There are three buttons saying "SET", "+", "-" on the control unit. In normal condition '+' is used for manually 'up' control, '-' is used for manually 'down' control. Numeric LED shows the barrier arm movement status ('0' for vertical, around '90' for horizontal) or the failure code.

- **Enter Programming mode**

Simultaneously press button "SET" & '+' to enter programming mode, the first default display will be function '1' (F1);

- **Select function**

At the status of function '1', every time you press "SET" button, the function code will add 1, from 1 to 9 and cycling. See below function code.

- **Set Parameter**

Under the selected function, press '+' or '-' to display value, within 10 sec. press '+' to increase parameter value, or press '-' to decrease value. Press 'SET' to save and return to "select function" status.

- **Exit Programming mode**

Simultaneously press 'SET' & '-' to exit programming mode, or it will exit automatically if no input for more than 30s during programming.

**Scan below QR code to read manual of Parameter Programming**



**Function code:**

- F1--- Deceleration Point For Open (Default value: 35)  
Inappropriate value may cause too slow open or strong shake
- F2--- Deceleration Point For Close (Default value: 60)  
Inappropriate value may cause too slow close or strong shake
- F3---Value of Auto-Reverse on Obstacle(Default: 50)  
Value 12~99, the more value the less sensitive. 99 to close
- F4---Address: 1~99. (Default: 99)

- F5---Automatic close in given time (Default 99)  
Value 1-99 sec., this function shut down at 91-99 sec.
- F6---Up speed, 0~60, the smaller value, the faster speed  
(Default 10 for 50 ratio, 20 for 100 ratio)
- F7-Down speed, 0~60, the smaller value, the faster speed  
(Default 10 for 50 ratio, 20 for 100 ratio)  
Any number between 0~60 can be set.  
For example, 10 for 1 sec. 15 for 1.5sec, 60 for 6 sec.
- F8-Loop detector N/O or N/C setting  
0: Loop detector #1 N/O; 1: Loop detector #1 N/C
- F9---Loop detector filtering time, 0~6, unit is sec. (Default 0)  
the larger value, the longer filtering time, invalid when 0
- C0---Arm direction setting, 0 is rightward, 1 is leftward  
(Default: Set according to customer order)
- C1---Relay function setting (Default 10)  
**Change into 00 if barrier is connecting to parking system.**

Value	RL1 Relay	RL2 Relay	RL3 Relay
00	Traffic light	Loop detector feedback	None
01	Boom movement reminder output (Flashing Light & Siren)	Loop detector feedback	None
10	Traffic light	Boom open fully	Boom close fully
11	Boom movement reminder output (Flashing Light & Siren)	Boom open fully	Boom close fully

- C2-- Alway-open Mode of remoter (Default 0)  
0 disable, 1 enable
- C3--Memory of Repeated Opening (Default 0)  
0 disable, 1 enable
- C4--Reduction Radio (Default: according to customer)  
0 for 50:1 reduction radio, 1 for 100:1 reduction radio
- C5~C9 For manufacturer usage only!  
Do not modify them, or it may cause problem.

\* Advanced menu C0~C4 won't be shown unless continuously press button "SET" for 6 Sec. under function mode

\* Barrier should be reset (power off and power on again) after setting of C0 & C4.

If the barrier is equipped with "module for automatic opening in case of power off", then Pls. power on barrier again only after the controller Nixie Tube turns off.

## 6.7 Self-Learning Remote Control

There are two types of remote control as below:



Self-learning



No-self-learning

### 6.7.1 Self-Learning Remote Control (Lower right corner of remoter control is \* )

1. Continuously press button "SET" and then press "+" to enter programming mode, the first default display will be function "1" (F1).
2. Under F1 status, continuously press "SET" button for 6 Sec. and then release the same, to enable advanced menu C0, and then press "SET" button to select C7.
3. Press "+" button once to enter C7, the Nixie Tube will show quantity of remote control code which has been stored in the barrier controller.
4. Press "+" button once to start self-learning, and continuously press "STOP" button (□) of remote control till one of indicators on the barrier controller flash.
5. Repeat the step 4
6. Press "-" button three times to clean all codes
7. Exit self-learning: Press "SET" button once to return to "Select Function" status, and press "SET" button firstly and then press "-" button to exit programming mode.

#### Tips for Self-Learning Remote Control:

1. You have to self-learn the remote control again if you replaced the barrier controller
2. One barrier controller supports Max. 5 pcs. Self-Learning Remote Control

### 6.7.2 No-self-learning Remote Control (Lower right corner of remoter control is □)

Remote control and receiver have to be coded by welding.

# 7 Maintenance and Repair

## 7.1 Maintenance

Check the following items on a regular basis every three months:

### 1) Screws loosening

Open the barrier's top cover and control the barrier up and down. Visually check if the spring tie screw is loose, and if link rod retaining ring is in right position. The loosening of link rod screws and retaining ring will cause the boom to fall uncontrolled or even cause a vehicle accident.

If loose, firstly turn the power off, then manually fasten the loosed screws and power on.

### 2) Rubber Cushion damaged

Open the barrier's top cover, control the barrier up and down. Visually check whether the Rubber Cushion is damaged while active arm hit it. If damaged, should spin out the old damaged rubber Cushion and replace it with a new one.

### 3) Springs balancing

Turn the power off temporarily, put the boom arm at the position between 40~45 degrees angle to the horizontal and check whether the boom arm can keep static hanging balance. If can not keep balance, need to adjust the springs balance (Refer to 6.3 Adjust boom length)

### 4) Controller Board displaying

While barrier is working, visually check whether the controller Board's numeral LED normally displays angle value barrier boom arm moving. If there is fault code displaying, find the reason and deal it. (Refer to 6.6 Circuit Self-test)

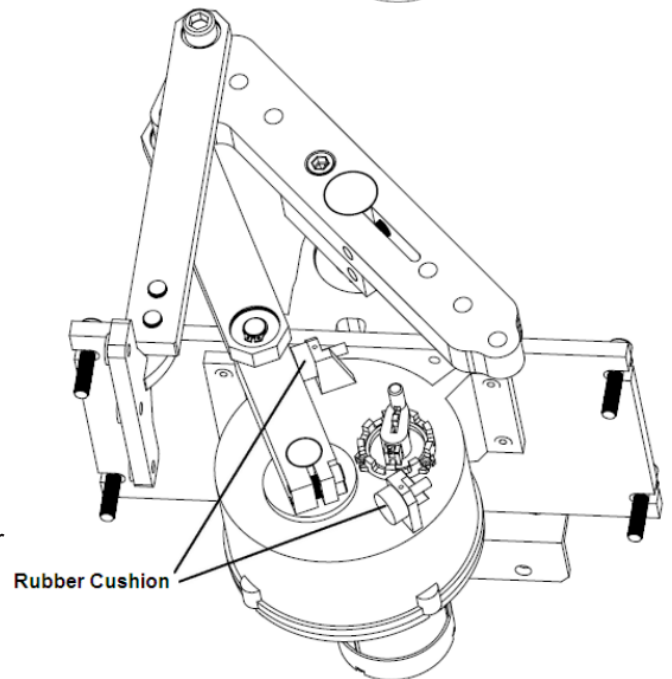
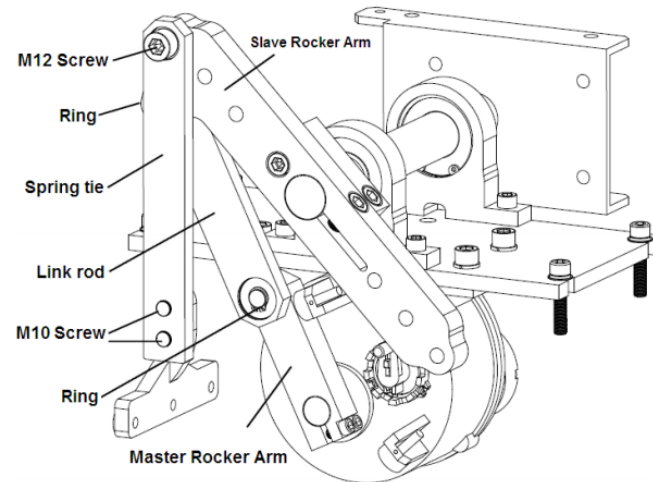

## 7.2 FAQs and Troubleshooting

### FAQ 1: Turn back halfway while the boom arm is moving down.

**Possibility:** 1. If F3 value is less than 25, maybe the pressure resistance rebound threshold is too sensitive, so triggered it by boom inertia or wind blowing.  
2. Springs tension is too tight

**Solution:** 1. Increases the threshold value of pressure resistance rebound to 50.  
2.Reduce the spring tension according to balance adjusting instructions. (Page 12: 6.3 / 2 )

### FAQ 2: Boom arm cannot open and close, also controller board LED display E1 fault code.

**Possibility:** 1.If boom arm can't move up after power on but manually moving it can make the controller display the moving angle value, indicates that the motor is damaged.  
2.If boom arm moves slowly, but controller board LED does not display the moving angle value, indicates that the pulse angle sensor is damaged.

**Solution:** 1. Replace motor.  
2.Replace angle encoder which is on the motor

### FAQ 3: Boom arm shock hardly when it starts to open or close

**Possibility:** 1. Boom arm was not tightly fixed onto the barrier housing.  
2.Transmission devices inside the barrier was loosen.  
3.Balance spring was broken.

**Solution:** 1.Check and re-fixed the boom arm onto the barrier housing tightly.  
2.Adjust the Limit Screw of Transmission device and Rubber Cushion.  
3. Replace the same balance spring.

### FAQ 4: Boom cannot move, cannot be controlled by remoter, but can be controlled by Entry Station

**Possibility:** 1.The battery of remoter (transmitter) has run down.  
2.The remoter (transmitter) got damaged.  
3.The remoter (receiver) got damaged.  
4.The controller board got damaged.

**Solution:** 1. Observe whether the indicator of remoter (transmitter) is on or off when press its button.  
If indicator is off, check whether the battery has run down, or the antenna is in good condition.  
2.Each barrier will be equipped with two remoter (transmitter) If the customer bought.  
If both two transmitters do not work, it means receiver may got damaged.  
3. If the receiver on the controller board ticks when press remoter (transmitter), it means the receiver is working, and controller board may got damaged.

### FAQ 5: Boom can be controlled by remoter and software, but can not be controlled by Entry Station

- Possibility:**
- 1.The loop detector of entry/exit station got damaged.
  2. The loop detector cable got open circuit or short circuit.
  3. No event upload when swiping card, or invalid card.

- Solution:**
1. Whether the loop detector cable is activated when swiping the card, and after activating the loop detector cable, observe whether the indicator light on the loop detector is always on. If there is no constant light, the loop detector or loop detector cable has a problem. Power off, and interchange the loop detector of barrier gate with entry/exit station. If it works normally, it means the loop detector got damaged; if the same, it means that there is a problem with the loop detector cable, and it may be broken or short-circuited
  - 2.When the loop detector detects the activ loop detector coil, check whether there is an LED light up on the control board. If there is, check whether there is event upload on the computer, whether it is a valid card reading. If there is no event upload, it should be a problem with the card reader. If there is an event upload, check the uploaded event, whether it is an expired card, already entered card or invalid card.
  3. If there is no event upload, check whether the card reader is normal.

## 8. Mechanical Explosion Drawings and Parts List

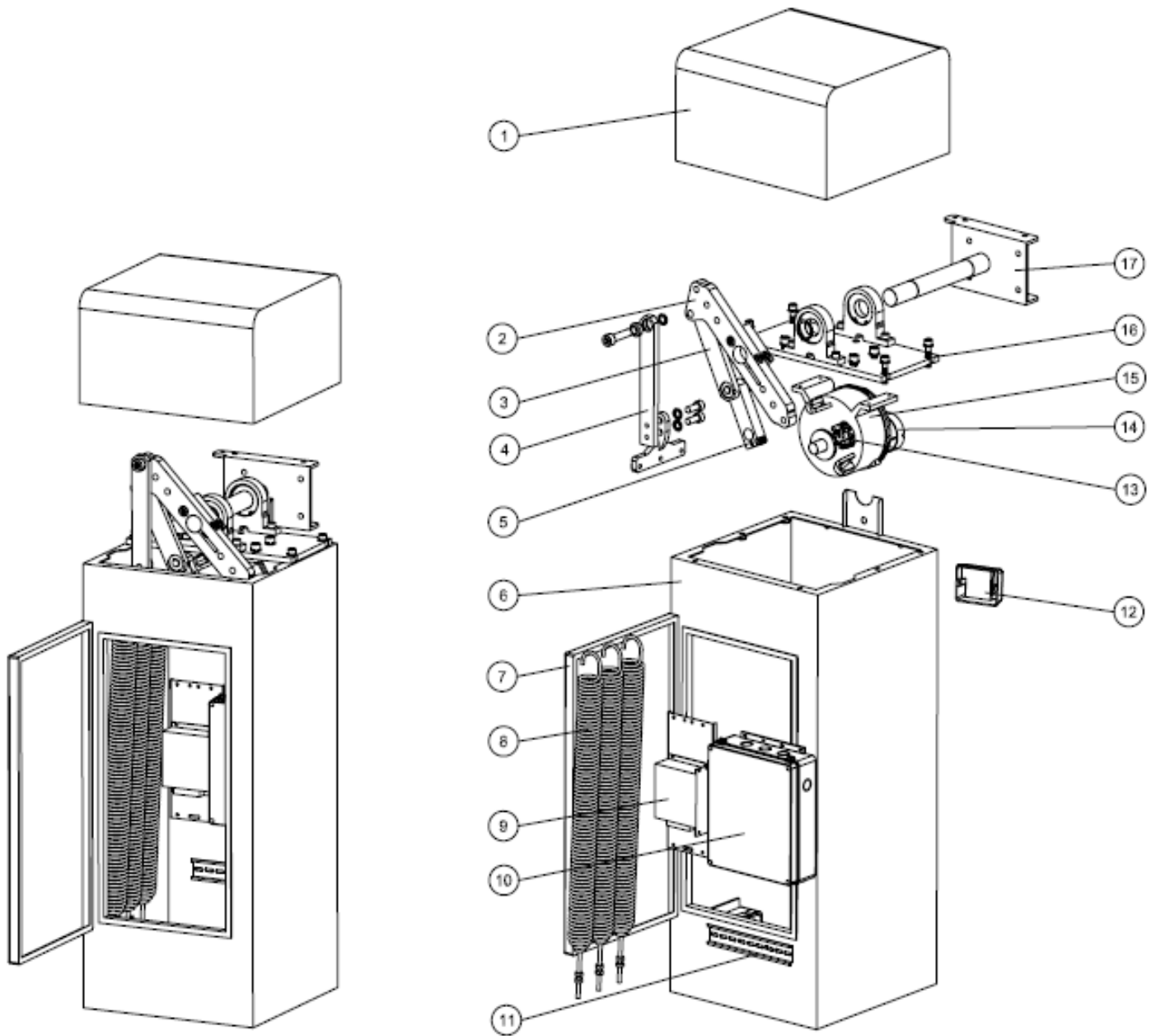



## Mechanical parts list

Serial	Part Name	Serial	Part Name
1	Top cover	14	Brushless servo motor
2	Slave rocker arm	15	Reducer
3	Link rod	16	Pedestal
4	Springs tie	17	Arm holder(includes main shaft)
5	Master rocker arm		
6	Housing		
7	Door		
8	Springs		
9	Switching mode power supply		
10	Controller board		
11	Earthing		
12	Remote receiver		
13	Manual handle		

# 9. Electrical Diagram and Parts List

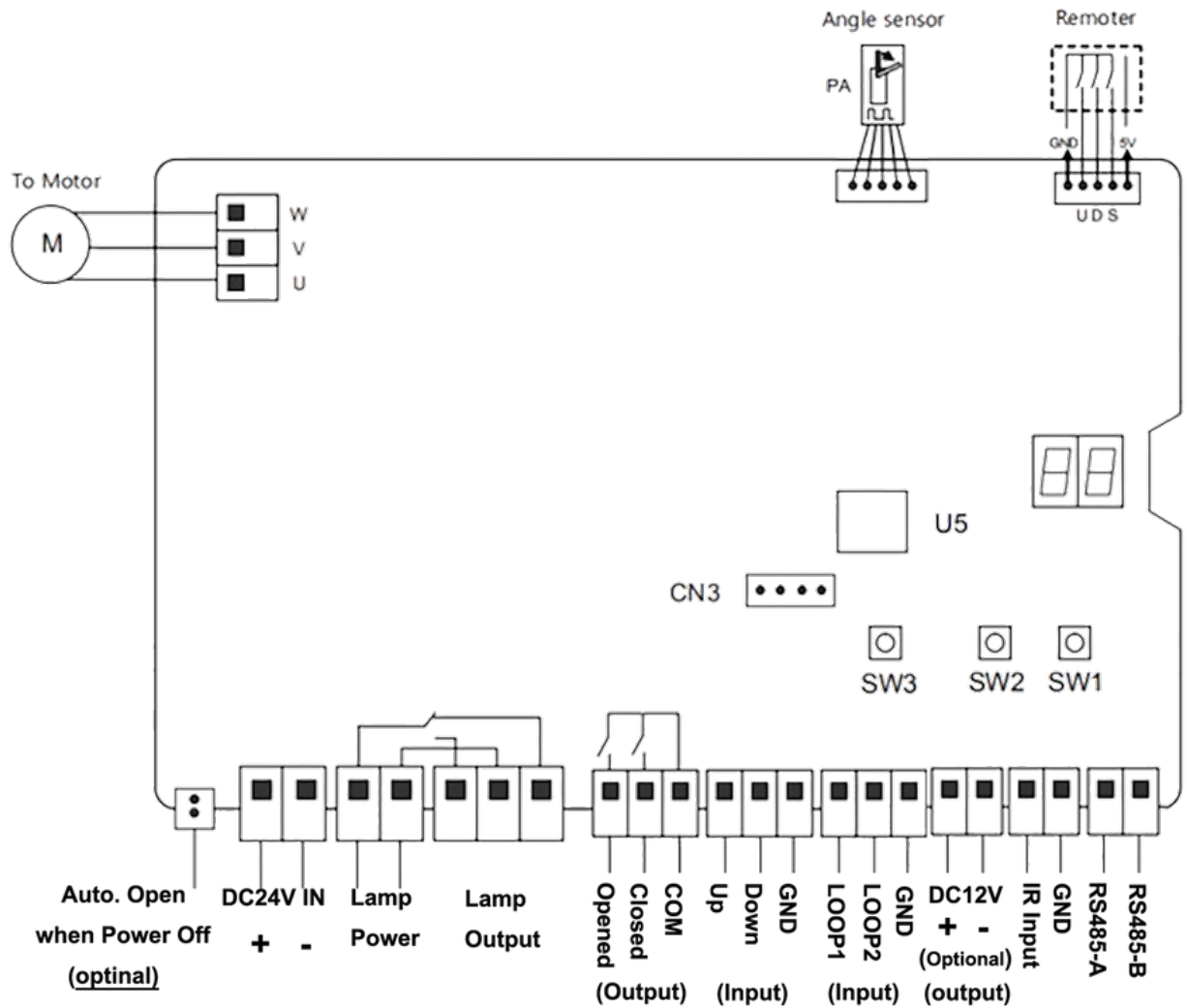

## Circuit parts list

Code	Name
SW1	Up Button
SW2	Down Button
SW3	Set Button
U5	Control Chip
CN3	Wifi / RJ45 module interface
M	Motor
PA	Angle Sensor